

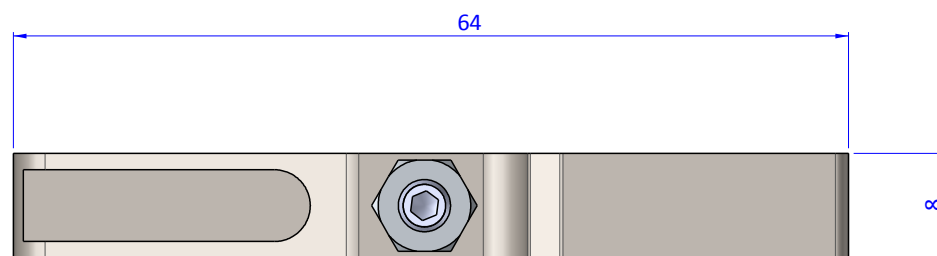

Item	Name	Q.ty
1	D.4	1
2	GTS.1003.14	1
3	PAP.0405504	2
4	R.4.SCH	1
5	V.STM4X16	1

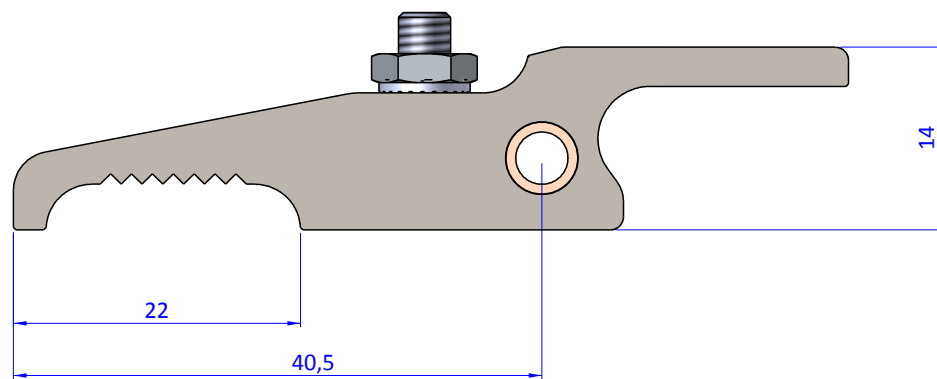
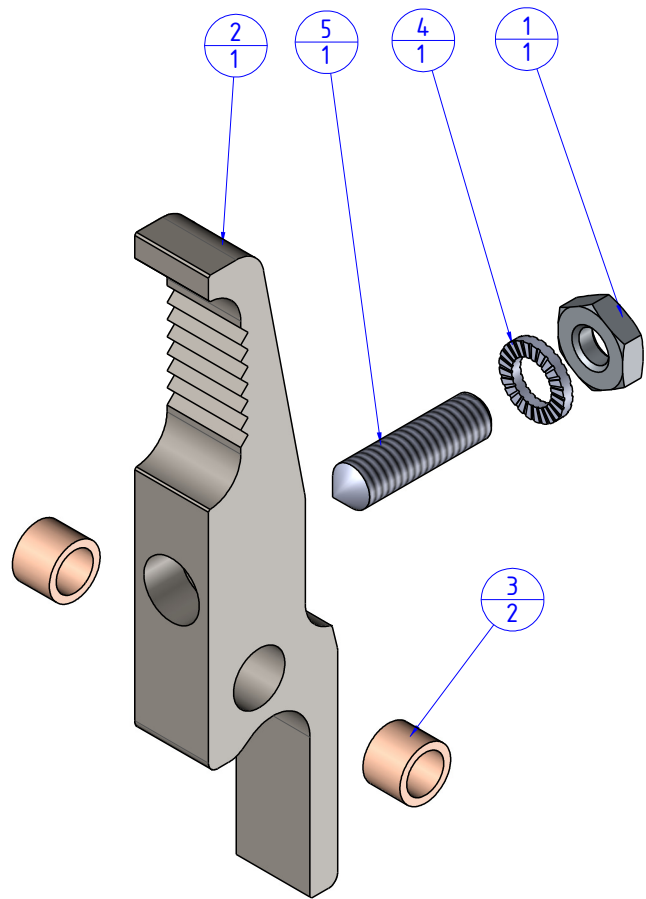

THE PROPERTY OF THE DRAWING IS ESTABLISHED BY LAW. IT IS FORBIDDEN TO PRODUCE OR SHOW IT TO THIRD PARTY, WITHOUT A WRITTEN AGREEMENT.

Format A3

UNI 936-76

 <b>FPS</b> FPSERVICES AUTOMATION		DESIGNED FROM		REVIEW
		FPS Automation		A
GENERAL TOLERANCE		DATE	WEIGHT	
UNI - ISO 2768		13/03/2019	0,024kg	
CLASSE f		CODE		
		GTS.03.14		GTS.03.14